



DOMINATOR FUEL PUMPS

P/N 12-1400 & 12-1800

Installation Instructions 199R10573

WARNING! THESE INSTRUCTIONS MUST BE READ AND FULLY UNDERSTOOD BEFORE BEGINNING INSTALLATION. FAILURE TO FOLLOW THESE INSTRUCTIONS MAY RESULT IN POOR PERFORMANCE, VEHICLE DAMAGE, PERSONAL INJURY, OR DEATH. IF THESE INSTRUCTIONS ARE NOT FULLY UNDERSTOOD, INSTALLATION SHOULD NOT BE ATTEMPTED. PLEASE CONSULT HOLLEY TECH SERVICE OR A QUALIFIED MECHANIC.

NOTE: NOT FOR USE WITH METHANOL! Will work with E-85!

APPLICATIONS:

Part Number	GPH Flow at Rated PSI and 13.5V	Application	Fuel Compatibility	Compatible up to 18.5V	Holley Recommendations for Peak Performance													Max Amp Draw
					Max HP*		Pump Fitting Size		Minimum Recommended Line			Fuel Filter (Carbureted)		Fuel Filter (Fuel injected)		Recommended Regulator		
					Naturally Aspirated	Forced Induction	Inlet	Outlet	Inlet	Outlet	Return	Pre	Post	Pre	Post	Carb	EFI	
The pumps below do not have an internal bypass. A bypass style regulator and return line are required.																		
12-1400	155 @ 8PSI	Street/Race	Gasoline / Diesel	Yes	1830	1425	-10AN	-10AN	-10AN	-8AN	-8AN	162-572	162-571	162-572	162-570	12-847	12-848	23 AMPS
	122 @ 43PSI				1400	1125												
12-1800	105 @ 60 PSI	Race	Gasoline / Diesel	Yes	1250	975	-10AN	-10AN	-10AN	-10AN	-10AN	162-572	162-571	162-572	162-570	12-847	12-848	36 Amps
	190 @ 8PSI				2100	1600												
	156 @ 43PSI				1800	1400												
	140 @ 60 PSI				1600	1200												

PARTS REQUIRED FOR INSTALLATION:

- Pre-Filter
- Post-Filter
- Relay Kit (30amp minimum) – Holley P/N 12-753 or equivalent
- Fuel hose & fittings (Threads in pump are 7/8-14 (AN10) O-ring)
- Wire & connectors
- Mounting hardware

NOTE: These pumps are not serviceable in the field. Contact Holley tech service for fuel pump service.

INTRODUCTION:

Congratulations on your purchase of the **Holley DOMINATOR Fuel Pump**. This instruction sheet contains all the information needed to install this fuel pump. Please read all the **WARNINGS** and **NOTES**. They contain valuable information that can save you time and money. Holley Performance Products cannot and will not be responsible for any alleged or actual engine or other damage, or other conditions resulting from misapplication of the fuel pumps and fuel pressure regulators described herein. However, it is our intent to provide the best possible products for our customer; products that perform properly and satisfy your expectations. Should you need information or parts assistance, please contact Technical Service at 1-270-781-9741, M-F, 8 a.m. to 6 p.m. & Sat. 9 a.m. to 3 p.m. CST. Please have the P/N ready when calling.

NOTE: A screen type pre-filter (100 micron), a top quality post fuel filter, fuel hose and clamps, 12 gauge wire, fuel fittings, assorted terminals and a relay kit (12-753) is required to complete the installation of the Holley DOMINATOR fuel pump. These parts are not included with the fuel pump.

NOTE: These Holley DOMINATOR fuel pumps require the use of a bypass style fuel pressure regulator (Part number 12-847 for carbureted applications and 12-848 for EFI applications).

NOTE: The Holley DOMINATOR fuel pump utilizes o-ring sealed inlet/outlet ports. The ports utilize 7/8-14 (AN10) O-ring threads. These ports are not pipe thread, therefore **Do not use thread sealant**.

PUMP MOUNTING AND INSTALLATION:

The best location for mounting any electric fuel pump is the rear of the vehicle, near the fuel tank and in a position even with or below the bottom of the tank, allowing the fuel to be gravity fed to the pump. **The pump should be mounted on a solid member, such as the chassis, with the pump outlet pointing forward or upward.** Avoid exposure of the pump and fuel lines to moving parts and to any hot areas, such as the exhaust manifold. The pump should not be mounted in an enclosed area, such as the vehicle's trunk. Follow the steps below for mounting the pump.

WARNING! THE PUMP MUST BE PLACED WHERE INTERFERENCE BETWEEN THE VEHICLE'S BODY AND ITS CHASSIS MOVEMENT IS AVOIDED. THE PUMP AND ITS CONNECTING HOSES MUST NOT BE SUBJECTED TO LOW GROUND CLEARANCE, WHERE ANY FLYING ROCKS OR ROAD DEBRIS CAN CAUSE DAMAGE. FAILURE TO AVOID THESE HAZARDS WILL LEAD TO PUMP DAMAGE, WHICH COULD RESULT IN FIRE AND/OR PROPERTY DAMAGE, SERIOUS INJURY, AND/OR DEATH.

1. Select a mounting site as close as possible to the fuel tank and away from possible sources of heat as detailed previously.
2. A template of the pump mounting holes is included on the last page. Use the included paper template and drill (4) ¼ holes.
3. Mount the pump (outlet pointing forward) using (4) ¼ bolts (bolts not included).

NOTE: To ensure pump life and flow efficiency, a 100 micron pre-filter must be installed between the tank and the pump inlet. The filter should be supported in such a manner that it does not hang from the fuel lines. Pre and Post filters can be mounted directly to the pump if space allows.

4. Install the recommended AN fuel fittings. (Refer to the chart on page 1 for minimum recommended fuel fitting and hose size)
5. Connect the fuel supply line from the tank to the pre-filter and then to the inlet port of the pump. Connect the main fuel feed line to the outlet port of the pump, then to the post filter. See **Figures 1a and 1b**.

NOTE: Avoid unnecessary restrictions, such as sharp bends and undersized fuel fittings and hoses. Avoid routing fuel lines in areas that would cause chafing. All fuel line connections must be leak proof.

WARNING! IF SPLICING INTO EXISTING FUEL LINES, USE EXTREME CARE TO AVOID CONTAMINATING THE LINE WITH RUBBER OR METAL SHAVINGS, AS THIS WILL DAMAGE THE PUMP. IF THE FUEL LINE HAS BEEN CUT, IT IS ESSENTIAL THAT IT BE CLEANED TO ENSURE THAT NO METAL OR RUBBER PARTICLES ENTER THE FUEL SYSTEM. THIS IS PERFORMED BY BLOWING THE LINE CLEAN WITH COMPRESSED AIR. HOLLEY DOES NOT RECOMMEND THE PROCEDURE WHERE THE COIL WIRE IS DISCONNECTED, THE ENGINE IS CRANKED, AND THE FUEL IS COLLECTED IN A CONTAINER. SPARKING CAN OCCUR DURING THIS PROCEDURE, WHICH MAY RESULT IN A FIRE AND/OR EXPLOSION.

WARNING! DO NOT OVER TIGHTEN THE FITTINGS ON THE FUEL PUMP. TORQUE the fittings in the pump as follows. (-10AN to 360-400 in./lbs.)

USING A FUEL PRESSURE REGULATOR WITH A FUEL PUMP:

NOTE: A return style fuel pressure regulator is required for use with the Holley DOMINATOR fuel pumps. Please refer to the chart on page one for recommended fuel pressure regulators. Refer to figures 1a, and 1b, for recommended plumbing scenarios. .

NOTE: Refer to the installation instruction included with the fuel pressure regulator for steps on mounting and adjustments

NOTE: Depending on your application, choose one of the following examples:

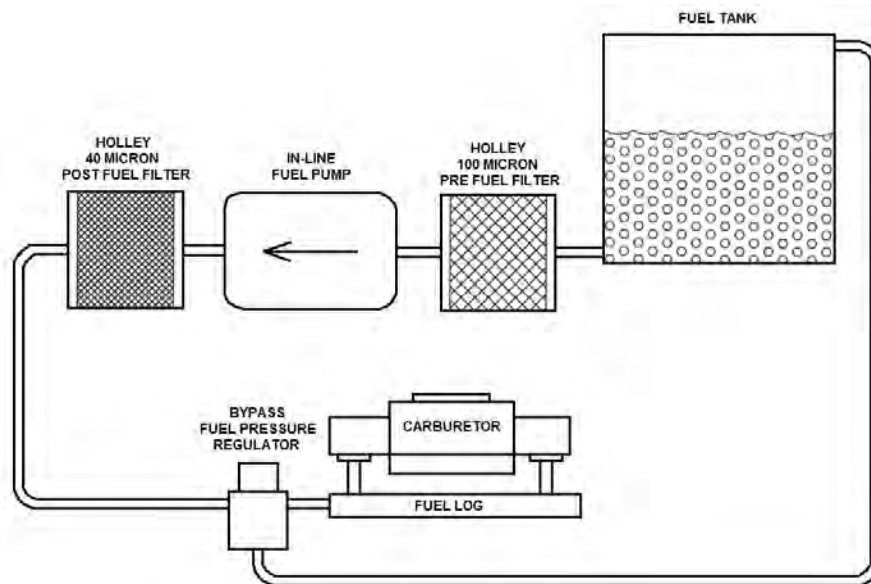

Figure 1a (Carb applications only)

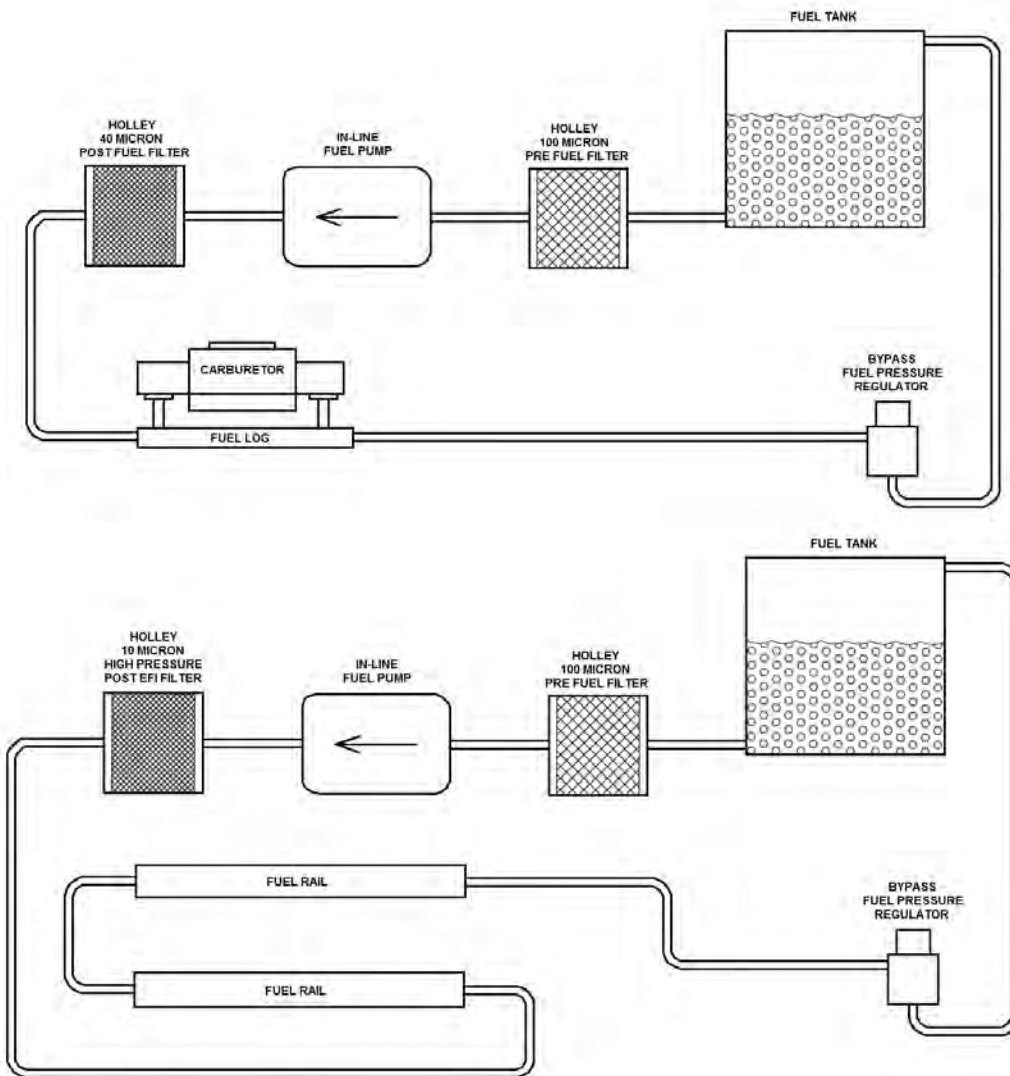

Figure 1b (Both carb & fuel injection applications)

WIRING:

WARNING! USE A MINIMUM OF 12 GAUGE WIRE. BE SURE TO CRIMP OR SOLDER ALL CONNECTORS SECURELY AND CLEAN ANY AREA WHERE GROUND LEADS WILL BE FASTENED. FAILURE TO USE THE MINIMUM WIRE GAUGE COULD RESULT IN A PUMP MALFUNCTION AND/OR ELECTRICAL FIRE, RESULTING IN PROPERTY DAMAGE, SERIOUS INJURY, AND/OR DEATH.

Holley Dominator fuel pumps have two internal pumps that can be wired independently or in unison. The advantage to having two pumps is the option of wiring one pump to supply the engine only, but when the additional flow is needed for nitrous activation, boost, etc, the second pump can be activated.

(1) WIRING THE FUEL PUMP WITH A RELAY: (Wiring both pumps together)

NOTE: You will need Holley Fuel pump relay kit P/N 12-753 30 AMP x 2 if wiring pumps individually, 534-26 40AMP if wiring pumps in unison or equivalent 4-wire relay.

1. Disconnect the cables from the battery.
2. Mount the relay on the firewall of the engine compartment or other suitable location using a sheet metal screw.

WARNING! Before punching or drilling a hole in the firewall, make sure you know what is on the other side to avoid puncturing equipment such as heater cores, air-conditioning system equipment, hoses, or wiring.

3. Connect the #85 terminal of the relay to a good clean ground.

4. Connect the #86 terminal of the relay to a switched 12V source.
5. Connect the red and orange wires on the pump to the #87 terminal of the relay.
6. Connect the #30 terminal of the relay the positive side of the battery. It is recommended that a 40amp fuse be placed in-line between the relay and battery.
7. Connect the black and brown wires from the fuel pump to a good clean ground.
8. Reconnect the battery cables.

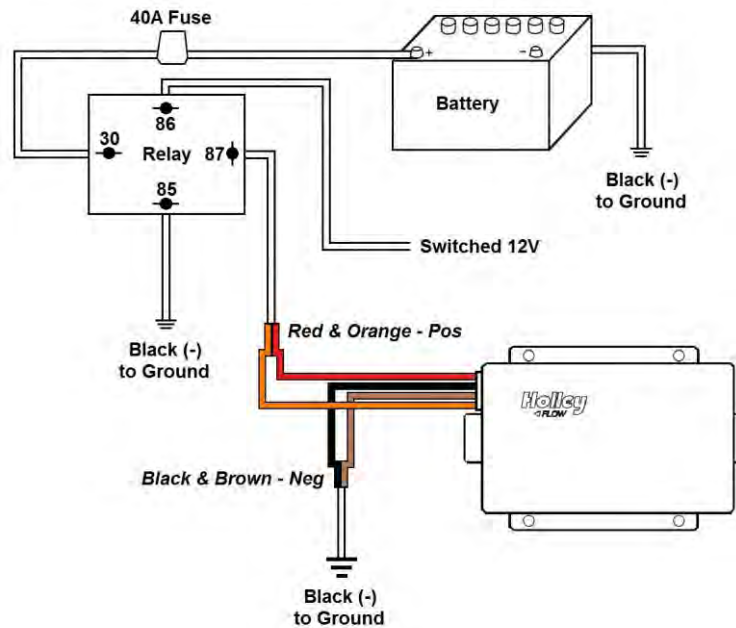

Figure 2

(2) WIRING THE FUEL PUMP WITH TWO RELAYS: (Wiring both individually)

NOTE: USE A MINIMUM OF 12 GAUGE WIRE. The following steps are if Holley 12-753 relays are being used. If relays other than the 12-753 are being used, refer to the instruction with the relay for proper wiring and/or wire colors.

1. Disconnect the cables from the battery.
2. Mount relays on the firewall of engine compartment using sheet metal screws.

WARNING! Before punching or drilling a hole in the firewall, make sure you know what is on the other side to avoid puncturing equipment such as heater cores, air-conditioning system equipment, hoses, or wiring.

3. Plug the fuel pump relay harnesses into the relays, until they lock into place.
4. Connect the black wire of the relay harnesses to a good clean ground using 12 gauge wire.
5. Connect the Green/Black wire of the relay harnesses to a switched 12 volt source. If one pump is being used as an additional fuel source while under boost or during nitrous use, connect the Green/Black wire of the relay for one pump to the 12V wire of the activation source.
6. Connect one of the red wires of the relay harness to the positive wire (red wire) of one fuel pump.
7. Connect one of the red wires of the 2nd relay harness to the positive wire (orange wire) of the other fuel pump
8. Connect the black and brown wires of the fuel pump to a good clean chassis ground using a ring terminal.
9. Attach the in-line fuse holders to the remaining red wires of the relay harnesses. After attaching the fuse holders to each wire, insert a 25A fuse into each fuse holder and connect to the positive side of the battery using 12 gauge wire.
10. Reconnect the battery cables.

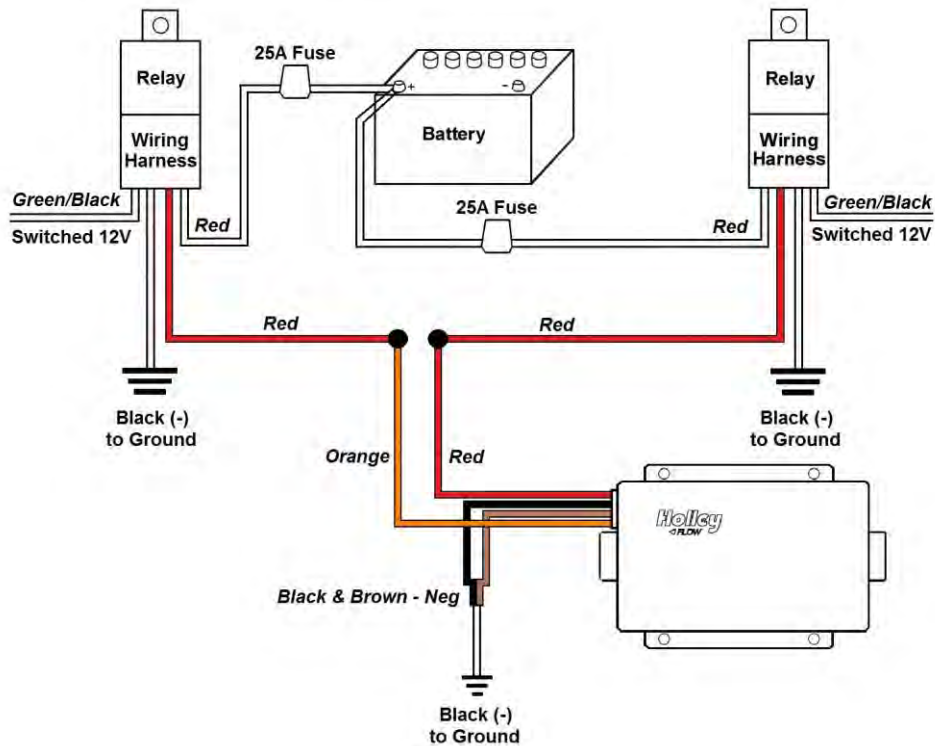
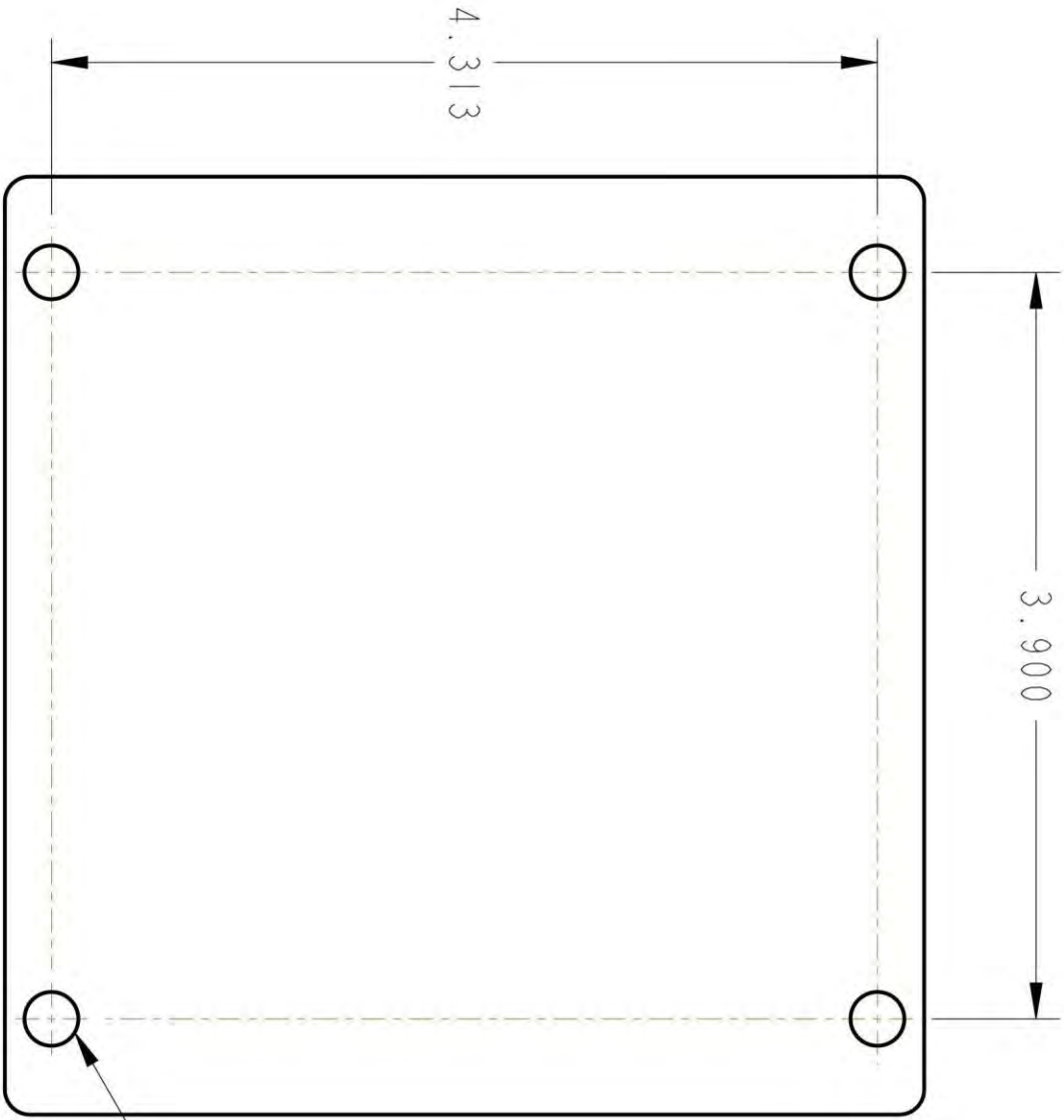

Figure 3

SERVICE PARTS AND ACCESSORIES:

ITEM	PART NUMBER
Chevy Small Block Mechanical Pump Block-Off Plate	12-814
Chevy Big Block Mechanical Pump Block-Off Plate	12-813
0-15 PSI Fuel Pressure Gauge (non-liquid filled) 1-1/2" Dia. 1/8" NPT	26-500
0-30 PSI Fuel Pressure Gauge (non-liquid filled) 1-1/2" Dia. 1/8" NPT	26-502
0-15 PSI Electric Fuel Pressure Gauge (dash mount)	26-503
0-15 PSI Fuel Pressure Gauge (liquid filled) 1-1/2" Dia. 1/8" NPT	26-504
0-30 PSI Fuel Pressure Gauge (liquid filled) 1-1/2" Dia. 1/8" NPT	26-505
30AMP Fuel Pump Relay Kit	12-753
90° Elbow for Attachment to Holley Fuel Line	26-69
Safety Shut Off Switch	12-810



DRILL (4) HOLES TO
ACCEPT 1/4" BOLTS

Holley Technical Support

Phone: 1-270-781-9741 Fax: 1-270-781-9772

Revision Date: 6-12-12

199R10573