



# INSTRUCTIONS

## COMP Cams® Max-Lift BSR Shaft Rocker System for GM LS Applications (Part #s 1981-16, 1982-16, 1983-16)

Thank you for choosing COMP Cams® products; we are proud to be your manufacturer of choice. Please read this instruction sheet carefully before beginning installation, and also take a moment to review the included limited warranty information. Contact us toll free at 1.800.999.0853 or at [www.compcams.com](http://www.compcams.com) under Tech Support with any questions.



<b>1981-16 BUSHED ROCKER ARM SHAFT KIT, GM CATHEDRAL PORT</b>		
<b>P/N</b>	<b>Description</b>	<b>QTY</b>
1981-8	LS1 BUSHED ROCKER SHAFT ASSEMBLY, STOCK ROCKERS	2
137024	BOLT, M8x1.25x45mm SHCS	16
COMP4-185	INSTRUCTION SHEET, COMP LS BUSHED ROCKER SHAFTS	1

<b>1982-16 BUSHED ROCKER ARM SHAFT KIT, GM RECTANGLE PORT</b>		
<b>P/N</b>	<b>Description</b>	<b>QTY</b>
1982-8	LS3 BUSHED ROCKER SHAFT ASSEMBLY, STOCK ROCKERS	2
137024	BOLT, M8x1.25x45mm SHCS	16
COMP4-185	INSTRUCTION SHEET, COMP LS BUSHED ROCKER SHAFTS	1

<b>1983-16 BUSHED ROCKER ARM SHAFT KIT, GM RAISED RECTANGLE PORT</b>		
<b>P/N</b>	<b>Description</b>	<b>QTY</b>
1983-8	LS7 BUSHED ROCKER SHAFT ASSEMBLY, STOCK ROCKERS	2
137025	BOLT, M8x1.25x35mm SHCS	16
COMP4-185	INSTRUCTION SHEET, COMP LS BUSHED ROCKER SHAFTS	1

Table 1 - Service Parts

SERVICE PARTS FOR COMP LS BUSHED ROCKER SHAFTS		
P/N	Description	QTY
137024	BOLT, M8x1.25x45mm SHCS	1
137025	BOLT, M8x1.25x35mm SHCS	1
1983S-1	BUSHED ROCKER ARM, LS7 STRAIGHT	1
1983R-1	BUSHED ROCKER ARM, LS7 OFFSET	1
1981-1	BUSHED ROCKER ARM, LS1/LS3 STRAIGHT	1
1982-1	BUSHED ROCKER ARM, LS3 OFFSET	1
500675809	LS7 BUSHED ROCKER SHAFT	1
500675808	LS3 BUSHED ROCKER SHAFT	1
500675807	LS1 BUSHED ROCKER SHAFT	1
1980-SR	RETAINING RING	1
1981-020-16	STEEL SHIM REPLACEMENT	1

### Installation:

1. With the valve covers off and old rocker arms removed, the first step will be to inspect the pushrods. COMP Cams® strongly suggests when installing new rocker arms (of any kind), that new COMP Cams® pushrods be incorporated to ensure that all mating surfaces are fresh to prevent any premature failures. To ensure your rocker arm warranty, it is necessary to install new pushrods with your new COMP Cams® Max-Lift BSR Shaft Rocker System. If you decide to use the old pushrods, examine the ends of all pushrods for any flaking or galling. Any imperfections on the ends of the pushrods will result in either rocker arm or lifter failure. **NOTE: Be sure to clean and blow-dry all pushrods. Also, blow through the pushrod to remove any foreign matter, such as sludge. Remember, in any type of engine work, cleanliness is imperative!**
2. Inspect rocker arm bolts, bolt bosses, etc. for excessive wear. Also, check the guide slots in the cylinder head for excessive wear. Wipe clean the tops of all the valves and again inspect each one for wear or mushrooming of the valve stem.

Movement of metal or galling of the bolts, pedestals or valve stem is a sign of excessive wear. Now is the time to make any decisions necessary regarding valve train components. Installing new rocker arms with questionable bolts or mushroomed valve stems is asking for trouble.

3. Remove the COMP Cams® Max-Lift BSR Shaft Rocker System from the package and wash the rocker assembly thoroughly with denatured alcohol (lacquer thinner). Do not use water or evaporative cleaners. Then blow dry. Soak the rockers in engine oil or spray with COMP Cams® Valve Train Assembly Spray (Part #106).
4. Lubricate the pushrods by coating both ends with a small amount of assembly lube. If the pushrod has an arrow, be sure to install it pointing up. It is recommended that all the pushrods be pre-oiled through the pushrod holes. Apply a small amount of COMP Cams® Assembly Lube to valve stem tips and rocker arm pushrod seats.

5. In order to begin checking valve lash or lifter preload with the COMP Cams® Max-Lift BSR Shaft Rocker System, you may install and check the pushrods one cylinder at a time. When a cylinder has been completed, remove and mark the pushrods, setting them aside until all cylinders have been checked.
6. Select a cylinder to begin adjusting the valves. Insert the intake and exhaust pushrod for that cylinder only. Install rocker arm shaft across rocker pedestals. Pay special attention to the pushrod and rocker arm positioning. Be sure that the pushrods are seated in the lifter and rocker arm seats. Loosely install the two rocker arm bolts for that cylinder only. Make sure to install the rocker arm bolts so that the bolt head is sitting on the flat surface of the shaft. Torque the rocker arm bolts to **30 N-m (22 lb-ft)**.
7. Adjusting valves: We recommend you work with one cylinder at a time. Follow the instructions below to ensure that the valves are properly adjusted.

**Hydraulic Lifter Cams and Pedestal-Mount Rockers:** When installing the rocker arms, ensure that you are using the proper length pushrod in order to obtain the optimal amount of lifter pre-load. **Lifter pre-load should be between 0.020" and 0.080". If yours is not, your application requires different length pushrods.** In order to measure lifter pre-load, it is best to use the following procedure.

- A) First, install the pushrods and torque both rocker arm bolts **for the chosen cylinder only**. Rotate the engine by hand in the normal direction of engine rotation until both the exhaust and intake valves have opened and closed completely. Allow a couple of minute for the lifters to bleed down. Ensure that both lifters are on the base circle of the camshaft before proceeding to the next step.
- B) Position a dial indicator so that the direction of travel is parallel with the pushrod. Place the tip of the dial indicator on the back of the rocker arm above the pushrod. Zero the indicator.
- C) Carefully loosen the rocker bolts, leaving the rockers on the head so that they will support the pushrods. As you slowly loosen the rocker bolts, the dial indicator should begin to travel up as the lifter releases its preload. When the pushrod stops travel upward, record the measurement on the dial indicator. This is the lifter preload. **Again, if preload is not between 0.020" and 0.080" your application requires either shorter or longer pushrods. Check with the lifter manufacturer to know their recommended preload for chosen set of lifters.**
- D) Once the lifter preload has been checked and is within the proper range, mark and set aside the pushrods for the completed cylinder. Repeat the process with the next cylinder. Continue this process until all eight cylinders have been checked.

**Solid Lifter Cams and Pedestal-Mount Rockers:** Traditionally, when running a solid roller lifter and camshaft with pedestal-mount LS rockers, custom length pushrods have been necessary to properly set valve lash. COMP Cams® has that problem covered with the XD-A™ Adjustable Pushrod line. The XD-A™ pushrod makes lash adjustment a breeze by using shims inside the 2-piece pushrod to control lash adjustment. Whatever your choice of lash adjustment, use the following procedure to properly set lash when using the COMP Cams® LS Bushed Rocker Arm Shafts.

- A) First, install the pushrods and torque both rocker arm bolts **for the chosen cylinder only**. Rotate the engine by hand in the normal direction of its running rotation until the exhaust pushrod just begins to move upward to open the valve. Stop rotation. The intake lifter is now on the base circle of the camshaft and the intake valve is ready to be adjusted.
  - B) Continue to turn the engine over until the intake pushrod moves all the way up. Rotate past maximum lift, approximately 1/2 or 2/3 of the way back down. The exhaust lifter is now on the base circle and the exhaust valve can be adjusted.
  - C) Once the valve lash has been checked and is within the proper range, mark and set aside the pushrods for the completed cylinder. Repeat the process with the next cylinder. Continue this process until all eight cylinders have been checked.
8. After lifter preload or valve lash has been checked and confirmed on all eight cylinders, install all the pushrods, being sure to match each cylinder with the pushrods used during the checking procedure. Again, be sure to have properly lubricated both ends of each pushrod.
  9. Install the COMP Cams® Max-Lift BSR Shaft Rocker System on the rocker pedestal. Pay special attention to the pushrod and rocker arm positioning. Be sure that the pushrods are seated in the lifter and rocker arm seats. Install rocker arm bolts loosely. Make sure to install the rocker arm bolts so that the bolt head is sitting on the flat surface of the trunnion. Draw each bolt down until it just touches the flat surface of the rocker shaft.
  10. Begin turning in each bolt 1 turn at a time, following the sequence shown in *Figure 1*, until the rocker shaft is fully seated on the pedestals.

**NOTE: Failure to follow the proper sequence 1 turn at a time could result in bent or broken components! The process shown is designed to prevent over loading any individual valve, rocker arm, or bolt.**

11. After the shaft has been drawn down to all pedestals, torque each rocker arm bolt to **30 N-m (22 lb-ft)** following the same tightening sequence shown in *Figure 1*.

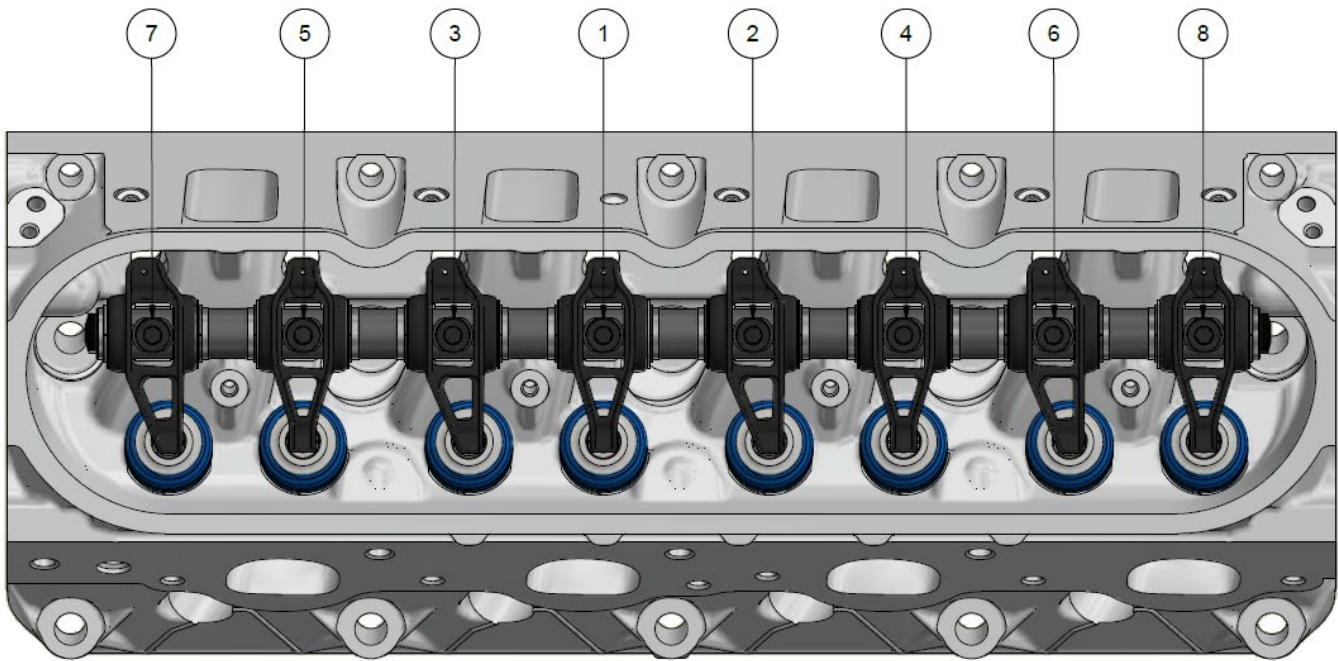

Figure 1 - Rocker Arm Bolt Torque Sequence

12. Before the valve covers are installed, be sure to pour engine oil on the rocker arms, making sure to coat the valve tips and rocker arm trunnions. This will ensure that the rocker arms will have adequate lubrication until the oil travels up from the motor.

**Warning: Always Check the Following Before Operation!**

- Old pushrods should not be used.
- Immediately upon startup, rocker arms must have adequate oil supply.
- Check pushrod-to-cylinder head slot clearance.
- Check rocker arm-to-valve spring retainer clearance.
- Check for valve spring coil bind. If this occurs, the correct spring must be installed.
- Be sure to check for proper rocker geometry.

**Special Instructions:**

1. The use of old pushrods may result in pushrod or rocker arm failure. It is necessary to install new pushrods with your new COMP Cams® Max-Lift BSR Shaft Rocker System to ensure your rocker arm warranty. Pushrod ends have a mated surface to the rocker arm ball socket, much like a camshaft and lifter mate to each other. This is why used pushrods should not be run with the new COMP Cams® Max-Lift BSR Shaft Rocker System.
2. On racing applications with dual springs, the rocker arms should be removed and inspected after the first hour of running time.

### Social Media

Stay up-to-date with the latest COMP Performance Group™ company and product information by following us on any of our social media platforms.

 [facebook.com/COMPWins](https://facebook.com/COMPWins)

 [twitter.com/COMPcams](https://twitter.com/COMPcams)

 [cpgnation.com](http://cpgnation.com)



### **Limited Warranty**

Competition Cams, Inc. warrants that all of its products are free from defects in material and workmanship, and against excessive wear for a period of (1) one year from the date of purchase. This **limited warranty** shall cover the original purchaser.

**Competition Cams, Inc.'s obligation under this warranty is limited to the repair or replacement of its product.** To make a warranty claim, the part must be returned within (1) one year of purchase to the address listed below, freight prepaid. Items covered under warranty will be returned to you freight collect.

**It is the responsibility of the installer to ensure that all of the components are correct before installation. We assume no liability for any errors made in tolerances, component selection, or installation.**

**There is absolutely no warranty on the following:**

- A) Any parts used in racing applications;**
- B) Any product that has been physically altered, improperly installed or maintained;**
- C) Any product used in improper applications, abused, or not used in conjunction with the proper parts.**

**There are no implied warranties of merchantability or fitness for a particular purpose.** There are no warranties, which extend beyond the description of the face hereof. Competition Cams, Inc. will not be responsible for incidental and consequential damages, property damage or personal injury damages to the extent permitted by law. Where required by law, implied warranties or merchantability and fitness are limited for a term of (1) one year from the date of original purchase.

This warranty gives you specific legal rights and you may also have other legal rights, which vary from state to state.